

# SEAHAWK

for Speed 400 med gear og Speed 500 - 600 med og uden gear

1:1

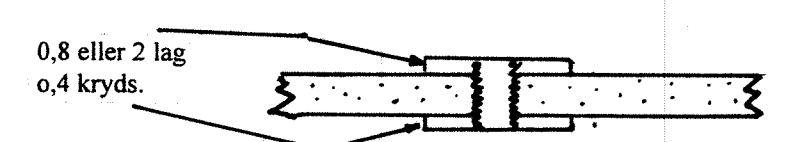
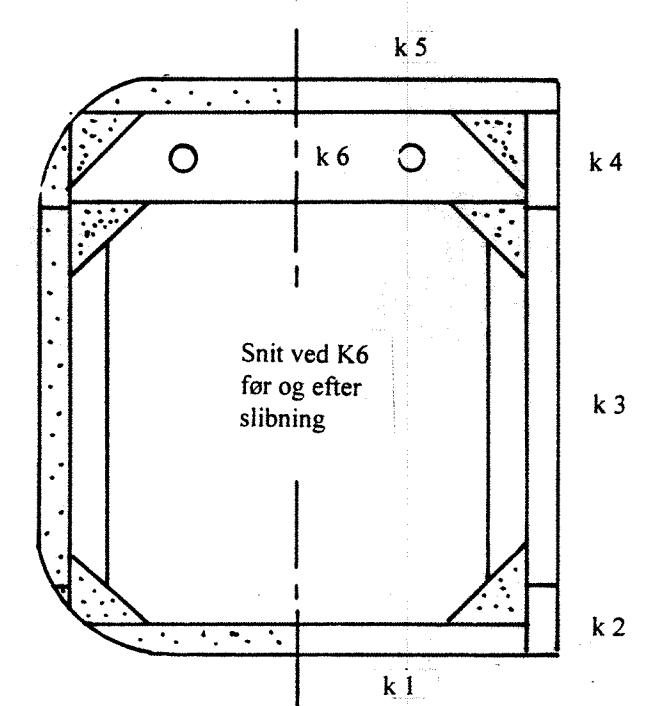
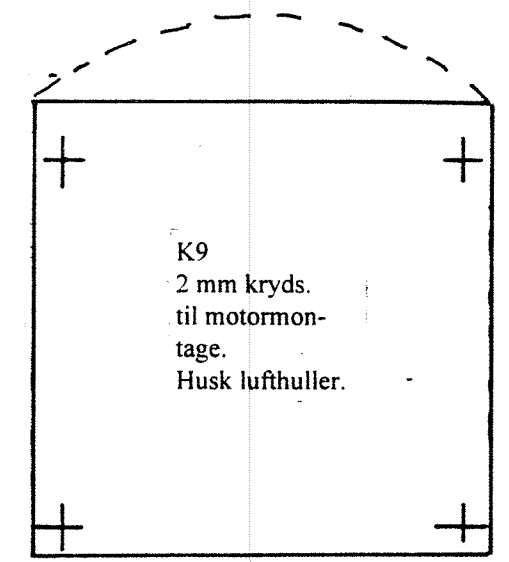
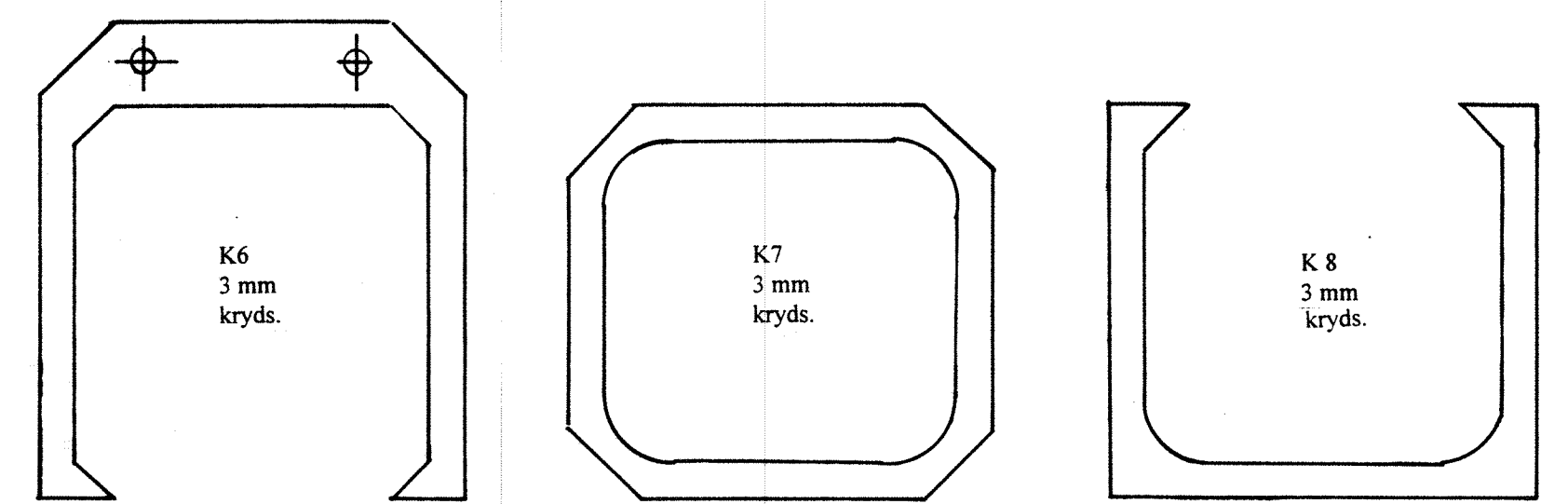
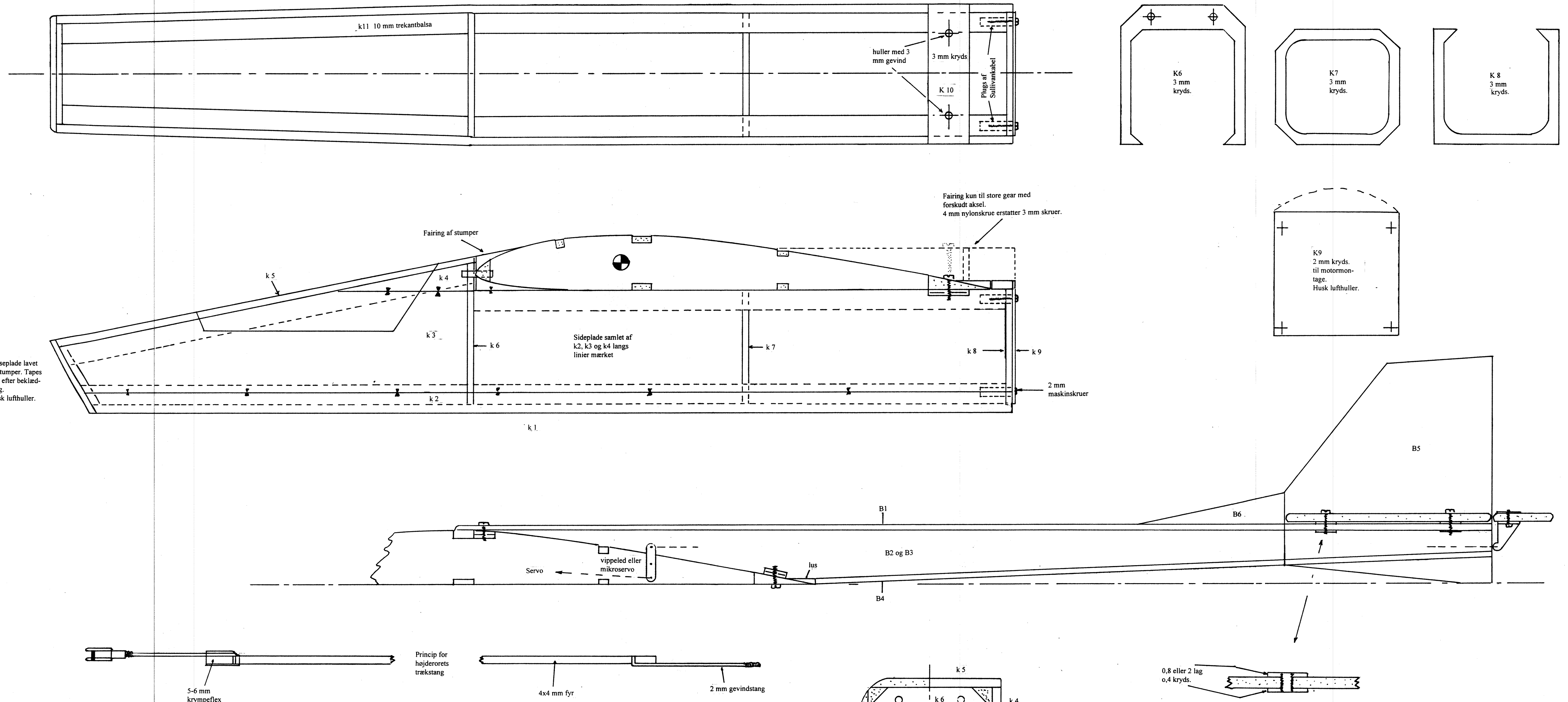

- Arbejdsgang ved skæring af 3 mm gevind i træ:
1. bor et 2 mm hul
  2. hæld hullet med tynd cyano
  3. skær gevind med 3 mm snittap
  4. hæld gevind med tynd cyano
  5. efterskær gevind med snittap eller 3 mm jernskrue

## Skæreplan 1:3

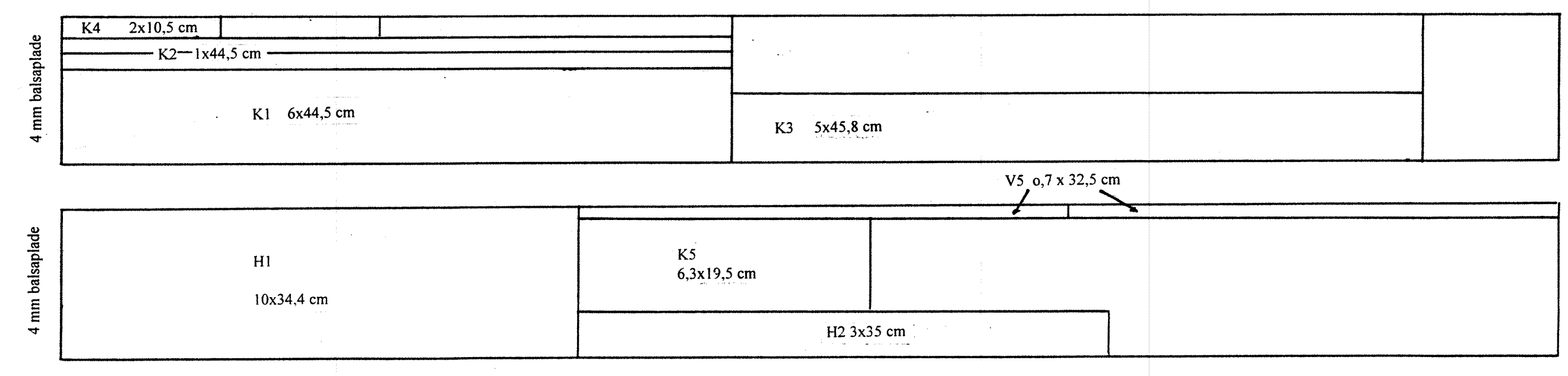
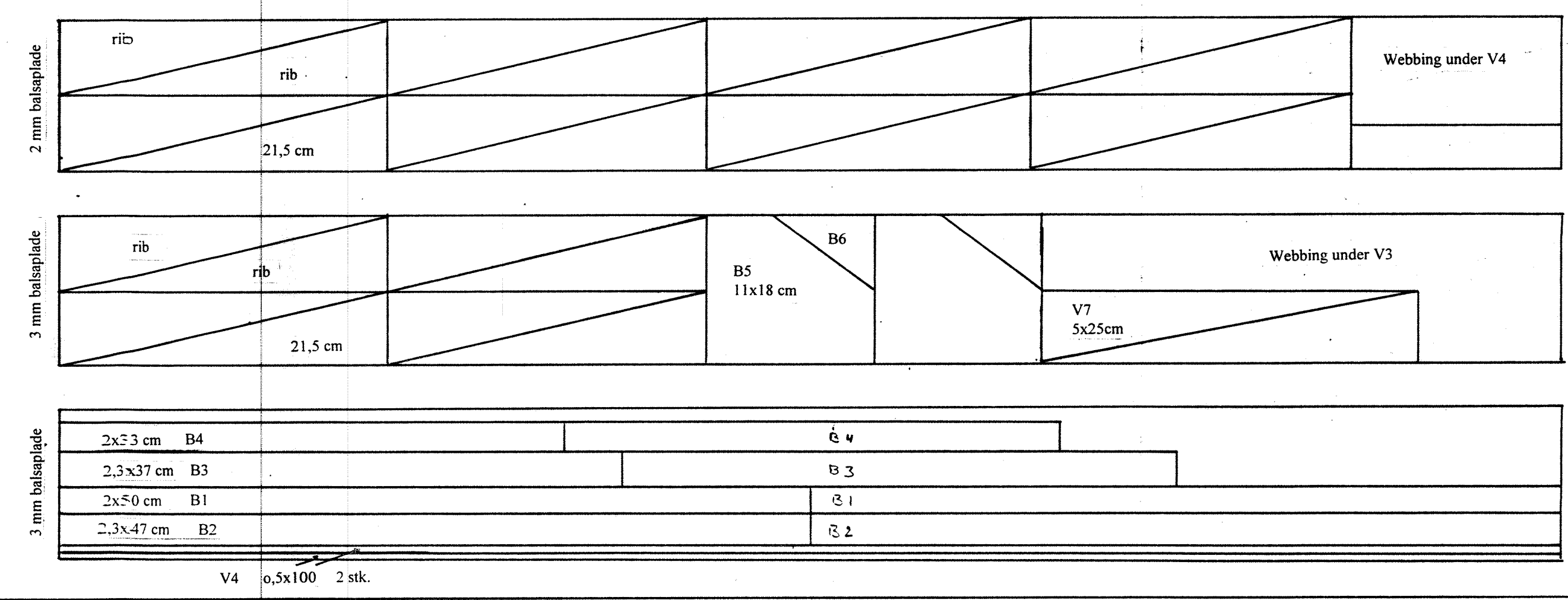

Lars Pilegaard  
86 615951